

Wheelie Bin - Large Capacity



Usage

Large size wheelie bins for commercial and industrial waste management applications.

Features & Benefits

- Ergonomic easy-grip handles
- Easy-open lid with full width handle
- 660-litre and 1100-litre MGBs are designed and manufactured to comply with AS 4123-2
- High quality UV-Stabilised HDPE construction prevents sun fade and cracking
- Smooth interior for easy emptying and cleaning
- Solid rubber-tyred swivel wheels, two with brakes and directional locks
- Heavy-duty castors for maximum manoeuvrability
- All container parts are recyclable
- Water drainage plug is standard
- Range of colours available

Specifications

660L Wheelie Bins

Dimensions: 1260mmW x 850mmD x 1250mmH

Wheels: 200mm solid rubber

Unit Weight: 43kg

Max. Load Capacity: 310kg

1100L Wheelie Bins

Dimensions: 1240mmW x 1070mmD x 1330mmH

Wheels: 200mm solid rubber

Unit Weight: 65kg

Max. Load Capacity: 440kg



BACKSAFE
australia



1300 305 314

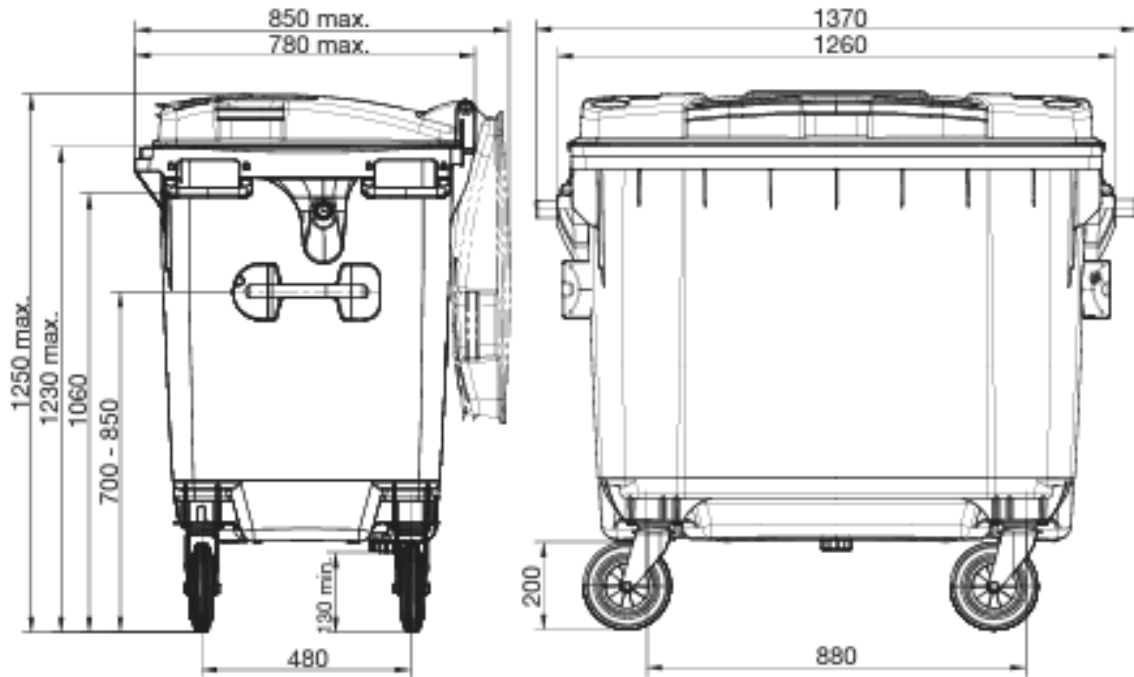

660L WHEELIE BINS

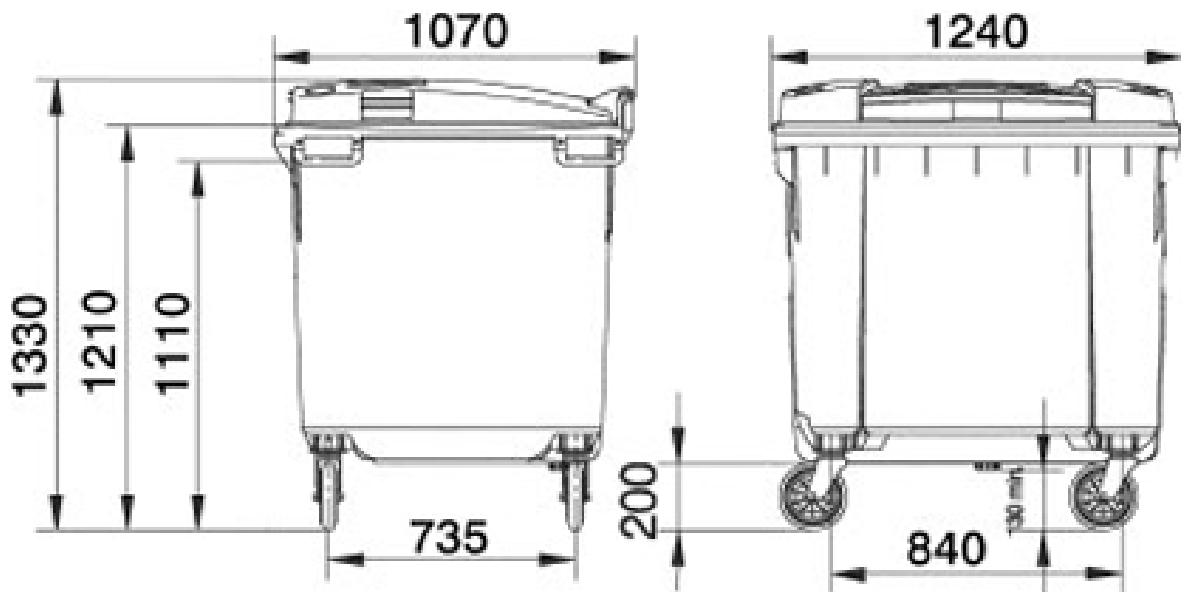

1100L WHEELIE BINS