

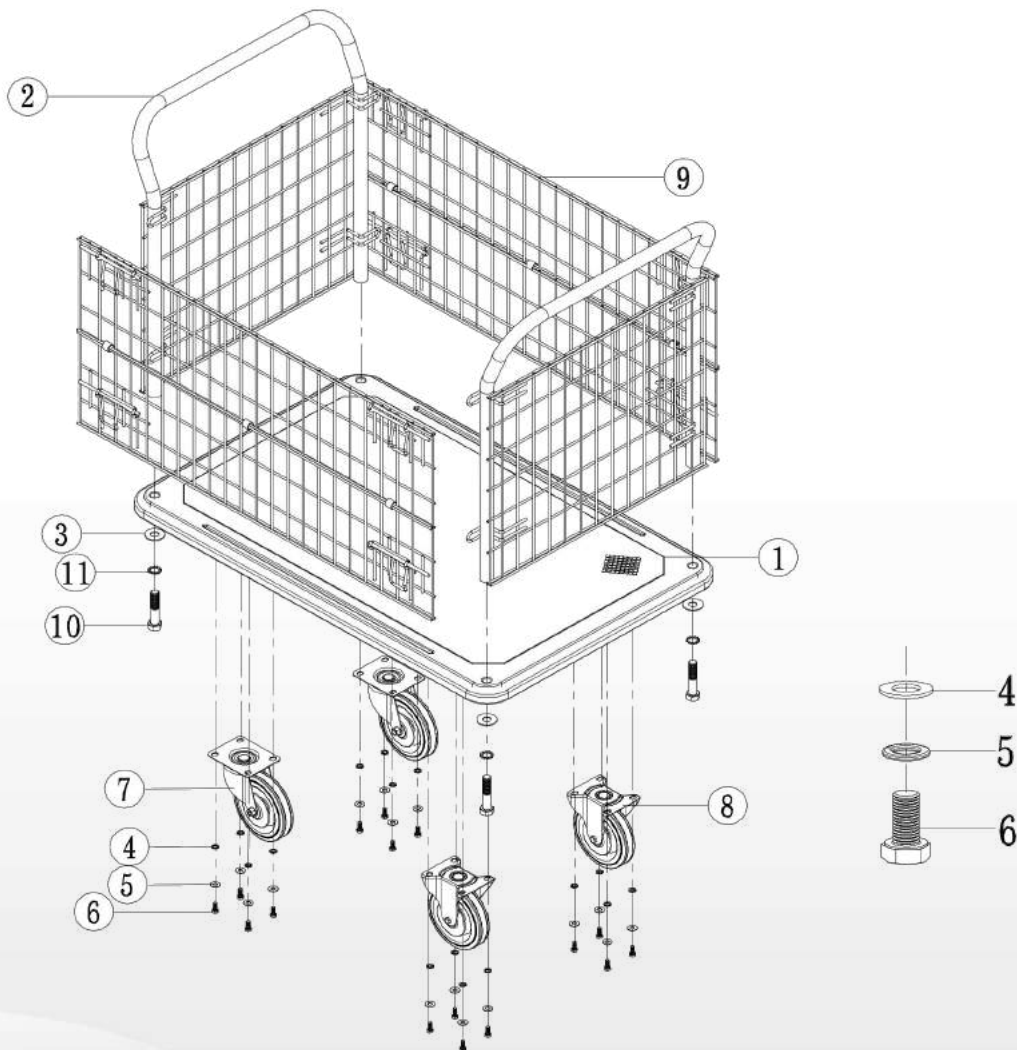

STURGO®

Assembly Diagram
Model: 12420016



No.	Description	Qty	No.	Description	Qty
1	Platform	1	7	Swivel Castor	2
2	Handle	2	8	Fixed Castor	2
3	Washer Support	4	9	Mesh Surround	4
4	Washer	16	10	Bolt	4
5	Spring Washer	16	11	Toothed Lock Washer	4
6	Bolt	16			