

STURGO[®] COMPACT ELECTRIC PALLET JACK 1.2T



WHY?

UPGRADE YOUR HAND PALLET JACK! EXCELLENT FOR FACILITIES HANDLING LIGHTER LOADS, YET STILL PROVIDES PREMIUM PERFORMANCE & EFFICIENCY

- Agile enough to manoeuvre the smallest warehouse
- Prevent costly accidents from manually lifting, lowering and carrying
- Save time and manpower with powerful 1.2 metric tonne capacity
- Simplified design to provide everything you need and nothing you don't
- Good for the environment - no nasty fuel emissions
- Quieter than combustion powered forklifts

KEY FEATURES

- Compact body for easy storage
- No unnecessary 'gimmicks'
- Stylish semi-enclosed design
- Powerful performance
- Tough long-lasting engineering
- Solid body frame
- Ergonomically designed handle with reversing horn and dual butterfly controls
- Unique easy exchange Lithium battery (spare batteries available to purchase separately)
- No hassle maintenance
- Drive time up to 3hrs, battery can be fully charged within 2.5hrs
- Comes with battery charger unit
- Electric drive / electric lift

TECHNICAL BRIEF

- Capacity 1200kg
- Battery voltage/rated capacity 20AH
- Electro-magnetic brake



Ergonomic handle



Stylish, compact drive frame

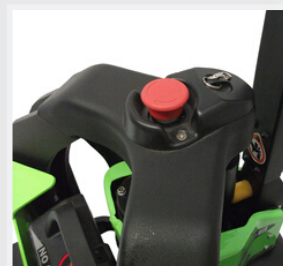

Magnetic key start



Removable Lithium battery



STURGO[®] COMPACT ELECTRIC PALLET JACK 1.2T

THE STURGO[®] LIFT RANGE

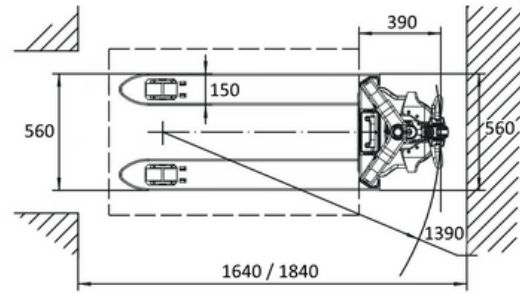
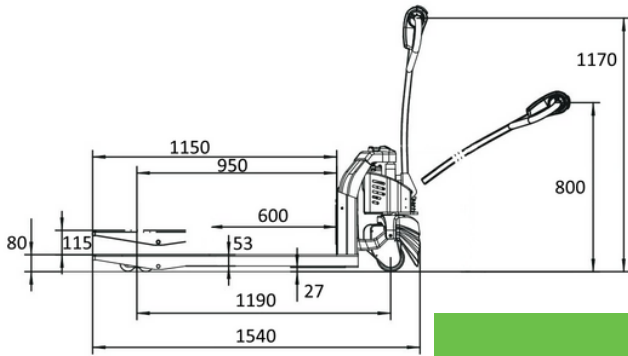

General

Model	11740259 / EPT12-EZ-3
Capacity	1200kg
Load Centre	600mm
Lifting Type	Electric
Operating Type	Pedestrian

Wheels

Material	PU
Wheel Base	1190mm
Quantity (driving/bearing)	1/2/4
Bearing Wheel	Ø80 x 60 mm
Driving Wheel	Ø210 x 70 mm

Dimensions

Min. Fork Height	80mm
Max. Fork Height	115mm
Overall Fork Width	560mm
In-between Fork Width	260mm
Fork Dimensions (length/width/depth)	1150/150/53 mm
Overall Dimensions (length/width/height)	1540/560/1170 mm
Min. Turning Radius	1390mm

Performance

Travel Speed (laden/unladen)	3.8/4 km/h
Lifting Speed (laden/unladen)	20/25 mm/s
Lowering Speed (laden/unladen)	60/30 mm/s
Max. gradeability (laden/unladen)	4/10%

Electrical

Drive Mode	DC
Drive Motor	24V 0.65Kw
Lift Motor	24V 0.5Kw
Battery Type	Li-ion
Battery Capacity	1 x 24V/20Ah
Charger	24V 10A

Weights

Battery Weight	3kg
Net Weight (includes battery)	135kg